

# Gold Series (AU-HV) Air Handlers

## Rust-Free, Anti-Slosh Drain Pan With Quick & Easy Installation



Completely redesigned for easier installation and improved performance, Gold Series air handlers, recipient of an Honorable Mention at the 2012 International Boatbuilders Exhibition and Conference (IBEX), incorporate many innovative features, including an optional Breathe Easy™ air purifier.

A rust-free, anti-slosh, positive-flow drain pan quickly removes condensate water and a third drain hole can be employed to further increase drainage. Each drain hole is reinforced and has an external stop to prevent over tightening of the screw-in hose barb.

To better accommodate a variety of installations, each drain hole can accept either a straight or 90-degree hose barb. In addition, the vibration-isolation mounting hardware can be attached at a variety of locations along the perimeter of the drain pan.

Gold Series AU-HV air handlers feature high-velocity (HV) blowers. The rotatable blower ring can be positioned easily by adjusting a single screw, and can even blow directly downward (best achieved with the right-oriented version). Optional DC "WhisperCool" blowers are available.

The blower inlet adapter is made of a high-temperature resin to easily withstand the heat generated by the optional internal electric heating element. Gold Series air handlers provide easy access to the manual heater-overload safety switch, which is accessible without disassembling the unit.

The optional integrated Breathe Easy air purifier is positioned directly in the airstream and uses ultraviolet (UV) light and photocatalytic nano-mesh technology to improve air quality without producing any harmful ozone. The award-winning Breathe Easy eliminates odors and up to 99.9% of VOCs and biological contaminants.



The drain pan features anti-slosh, positive-flow condensate channels, reinforced drain holes, and moveable vibration-isolation mounting clips.



The Gold air handler's HV blower can be easily rotated in the field by loosening the single adjustment screw on the blower collar (standard AU model shown).



The assembly for the optional electric heater (top) and Breathe Easy air purifier (bottom) fits between the coil and blower (standard AU model shown).

### Key Benefits

- Rust-free composite drain pan
- Drain pan features anti-slosh, "positive-flow" drain channels for no spills and rapid removal of condensate
- Vibration-isolation mounts reduce noise and vibration
- Improved insulation
- Single adjustment screw for 270° of blower rotation
- Blower can be rotated to straight down position for overhead applications
- Easy access to heater overload reset button
- Flexible mounting options
- Braided, kink-proof air bleeder hose
- Reinforced drain holes prevent overtightening of hose barbs

### Special Options

- Optional EU package upgrades include improved insulation and wire loom, protective cover for water-tube hairpins, and more (see reverse side for details)
- Optional DC "WhisperCool" blowers are extremely quiet yet powerful enough to overcome high-static-pressure duct
- Optional integrated Breathe Easy™ air purifier stops odors and is up to 99.9% effective in neutralizing contaminants in the air you breathe (not available for 6K BTU models)
- Optional electric heat
- Optional flow control automatically balances circulated water throughout the system
- Optional Breathe Easy™ microparticle air filter
- Left-oriented blower models



## Specifications for Gold Series (AU-HV) Air Handlers

Model <sup>(1)</sup>	AU6HV	AU9HV	AU12HV	AU18HV	AU24HV
Nominal Capacity - Cool (BTU/h)	6000	9000	12000	18000	24000
Nominal Capacity - Heat (BTU/h)	TBD	5118	6824	10236	10236
Voltage @ 50/60Hz 1-Ph (V)	230	115	230	115	230
Full Load Amps (FLA) Cool (A)	0.83	1.56	0.78	1.61	1.18
Full Load Amps (FLA) Heat (A)	5.18	10.26	4.96	9.84	14.22
Optional Electric Heat (kW)	1	1.5	1.5	3	3
Max. Circuit Breaker (A)	10	15	10	20	15
Min. Circuit Ampacity (A)	6	11	8	16	15
Water Flow (gpm/lpm)	1.5/5.7	2.3/8.8	3/11.4	4.5/17.1	6/22.8
Air Flow (cfm/m <sup>3</sup> h)	229/390	278/473	338/575	465/791	506/860
External Static Pressure	0.3/74.7	0.3/74.7	0.3/74.7	0.3/74.7	0.3/74.7
Chilled Water Pressure Drop (PSI)	1.1	4.4	8	4.6	11
Min. Height (in/mm)	11.19/285	13.31/339	13.31/339	13.94/355	15.25/388
Max. Height (in/mm) <sup>(2)</sup>	12.13/309	13.31/339	13.38/340	15.38/391	16.75/426
Max. Width (in/mm) <sup>(2)</sup>	14.5/369	16.5/420	16.5/420	20.13/512	22.63/575
Max. Depth (in/mm) <sup>(2)</sup>	12.56/320	13.25/337	14.25/362	15/381	15.38/391
Chilled Water Connection Size (in)	1/2	1/2	1/2	1/2	1/2
Min. Supply Duct Size (in/mm)	5/127	6/153	6/153	7/178	8/204
Min. Supply Air Grille Size (sq in/ sq cm)	35/226	49/317	70/452	100/646	140/904
Min. Return Air Grille Size (sq in/ sq cm)	70/452	98/633	130/839	200/1291	240/1549
Net Weight	0	0	30.5 lbs/13.9 kg	36 lbs/16.4 kg	0
Gross Weight	0	0	39 lbs/17.7 kg	45 lbs/20.5 kg	0

<sup>1</sup> Model numbers shown are for 115V units with high-velocity (HV) blowers. Add a 'Z' for 230V units; add '-FC' for optional flow control; add '-L', '-R', or '-...' for valve position (relative to the coil) and angle of the blower; add '...' kW for amount of optional electric heat in kilowatts (for ex. 1.5kW). See DWG #H3050002 for a visual explanation of valve orientation and blower angle.

<sup>2</sup> All dimensions ± 0.30 in. (8 mm).

## Dimensions

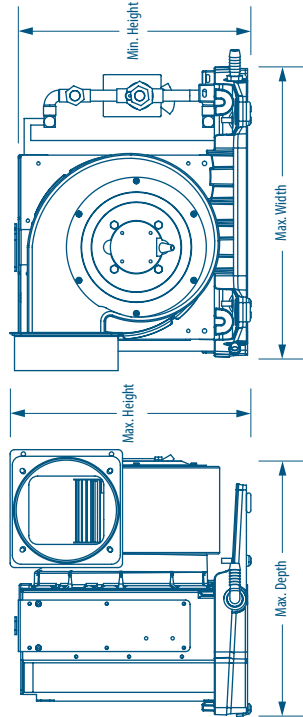

## DOMETIC MARINE DIVISION

2000 N. Andrews Ave. Ex. | Pompano Beach, FL 33069 USA | Tel. 954-973-2477 | Fax: 954-979-4414  
 www.Dometic.com/Marine | MarineSales@DometicUSA.com

## 24/7 TECH SUPPORT FOR UNITED STATES & CANADA:

8:00 AM to 5:00 PM Eastern Time: 800-542-2477  
 After hours and weekends: 888-440-4494

## INTERNATIONAL SALES & SERVICES

Europe & the Middle East: Call +44(0)870-330-6101  
 For all other areas visit our website to find your nearest distributor.

L-3022 Rev. 20141010

Specifications and availability subject to change without notice.

## About the EU Package

The EU Package includes several upgrades for reduced installation time and an improved appearance.

A plastic cover (A) protects the exposed water-tube hairpins. An upgraded wire loom (B) is used for better aesthetics and all electrical connections use quick-plugs (C) so there are no wires to connect. A new durable bleeder assembly with cradle (D) gives easy access and speeds the air bleeding process.

A capacitor, protected under a plastic housing (E), replaces the electrical box. In addition, a slave box can be used to control multiple air handlers from a single cabing control, all with plug-in connections. The plumbing connections (F) are shorter so the installation takes up less space.



## Key Benefits

- Quick-plug electrical connections
- Upgraded wire loom for improved appearance
- Less space needed for plumbing connections
- Easy access to bleeder assembly

Dealer

