

CATALOG 2018

MOBILE LIVING MADE EASY.

NEW PRODUCTS FOR CLIMATE, COOKING, AND
SANITATION THAT MAKE YOU FEEL AT HOME.

 **DOMETIC**

DEAR FREEDOM LOVER,

There are millions of people around the world who use Dometic products. You all have one thing in common. You're going some-where – whether you're an RV user, a boat owner, a truck driver or just a lover of the great outdoors. Our job is to meet your essential needs on the journey. Like cooking, keeping food fresh, taking care of personal hygiene and maintaining a pleasant temperature. That way, you can explore more, see more and stay away longer. We call it mobile living made easy.







CLIMATE

Do you love traveling in sunny weather? Enjoy your journey and the perfect climate in your recreational vehicle. Dometic air conditioners make sure you can.

PAGE 6 - 19



FOOD & BEVERAGE

Cook what you like, eat with friends, keep your provisions nice and fresh throughout the journey. We have taken care of every detail.

PAGE 20 - 33



HYGIENE & SANITATION

Enjoy a pleasant feeling of freshness wherever the road takes you. Reap the benefits of our decades of research into mobile sanitation systems.

PAGE 34 - 39

CLIMATE

Climate Control Gateway	8 - 9
9200 Power Awning	10 - 11
PowerChannel Accessories	12 - 13
Trim Line II Bag Awning	14 - 15
1400/1450 High-Powered Vent Fan	16 - 17
Mojave RV Furnace	18 - 19

FOOD & BEVERAGE

Drop-in Cooktop	22 - 23
Slide-In Cooktop	24 - 25
3-Burner Ranges	26 - 27
Americana & Americana Plus Refrigerators	28 - 29
CRX Series 3-in-1 Refrigerators	30 - 31
CD Drawer Refrigerators	32 - 33

HYGIENE & SANITATION

Moderno Toilet	36 - 37
Handwave Toilet Control Panel	38 - 39

DOMETIC ON THE WEB

Here's where you can find the complete Dometic range, with detailed information about all products. Plus, interesting facts about our company and download links for all our catalogs.

DOMETIC.COM

- / CLIMATE CONTROL GATEWAY**
- / 9200 POWER AWNING**
- / POWERCHANNEL ACCESSORIES**
- / TRIM LINE II BAG AWNING**
- / 1400/1450 HIGH-POWERED VENT FAN**
- / MOJAVE RV FURNACE**

CLIM



A photograph of a winter forest scene. The foreground shows a snow-covered road with dark tire tracks curving from the bottom left towards the right. The middle ground is filled with a dense forest of evergreen trees heavily laden with snow. The background shows a soft, orange and yellow glow from the setting or rising sun, partially obscured by the branches of trees. The overall mood is serene and quiet.

ATE

DOMETIC CLIMATE CONTROL GATEWAY

This is a network RV-C interface product for Single Zone Climate Controls and select Fan-Tastic Vent fans. Providing new networking capability for existing and future climate control products, the Dometic Climate Control (CC) Gateway allows Dometic air conditioners, furnaces and fan vents to be monitored and controlled from a single, centralized location.



SOPHISTICATED
DEVICE INTEGRATION

FLEXIBLE INSTALLATION
COMPACT

DIAGNOSTIC
CAPABILITY

CONVENIENT CLIMATE CONTROL FROM A CENTRAL LOCATION

Providing new networking capability for existing and future climate control products, the Dometic Climate Control (CC) Gateway allows Dometic air conditioners, furnaces and vent fans to be monitored and controlled from a centralized location. This could be a touch panel, tablet, and/or smart phone in suitably-equipped RV vehicles. Add the convenience of sophisticated device integration and enjoy complete comfort control at your fingertips.



KEY BENEFITS

- Versatile solution for networking Dometic climate control products RVs
- Compact design capable of installation in ducted, non-ducted and fan-only installations
- Diagnostic capability for furnace, air conditioner and gateway
- Uses RV-C (CANBUS) networking protocol which is open source and endorsed by RVIA
- Can be mounted in air conditioner's intake airway for ease of installation
- Remote temperature sensing allows for accurate temperature control and flexibility in placement
- Interfaces with single zone air conditioners, furnaces and fans



Multi-function gateway connecting air conditioning, furnace, and Fan-Tastic Vent fans



RV-C network connection for centralized user interface operations



Easy installation designed to mount in airway path



Alternate remote installation from air conditioner or utilize with Fan-Tastic Vent fan only

DOMETIC 9200 POWER AWNING

Dometic 9200 Power Awnings offer simple operation, smart design and technical superiority. Durable and stylish vinyl fabric provides shaded comfort.



**ONE PERSON
CONTROL**

DURABLE

SLEEK DESIGN

ENJOY SHADE ON DEMAND

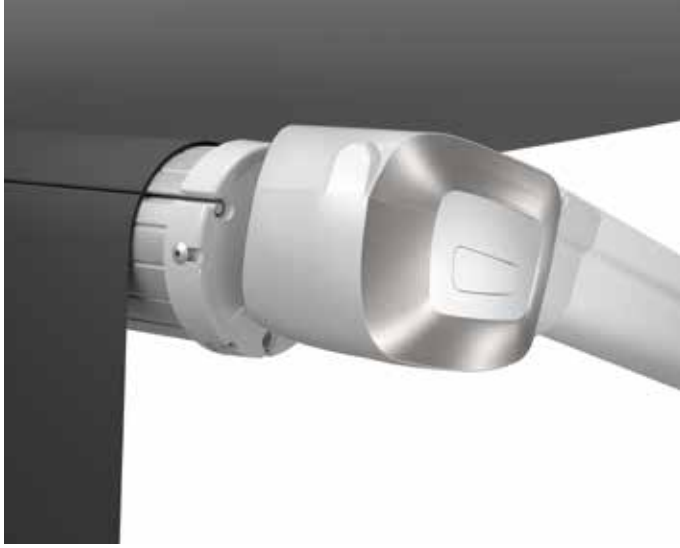

Dometic 9200 Power Awnings feature a newly-designed motor with increased speed for convenient, one-touch operation. Comes with durable, mildew proof and moisture resistant vinyl fabric for protection against the elements. Improved manual override ensures the ability to operate the awning in power outage situations.

Dometic 9200 Power Awnings are offered in sizes ranging from 8 ft to 21 ft for your convenience. Note: Awning comes with fabric and rollertube only, hardware (arms) sold separately.

KEY BENEFITS

- Faster operation than competitor awnings in the market today
- Easily set up by one person
- Quiet operation
- Durable, weather resistant vinyl fabric
- Improved manual override
- Sizes range from 8 ft to 21 ft widths
- Standard or basement hardware (sold separately)

AWNING	POWER AWNING	POWER AWNING WITH POWERCHANNEL TECHNOLOGY
Model Series	9200	9200 PowerChannel
Projection	8 ft / 2.4 m	8 ft / 2.4 m
Drive Mechanism	Motorized drive assembly	Motorized drive assembly
Drive Control	3 Position, Momentary ON, Center OFF DPDT Rocker Switch	3 Position, Momentary ON, Center OFF DPDT Rocker Switch
Power Source (including PowerChannel)	12V DC	12V DC
PowerChannel Control		SPST ON-OFF Illuminated Rocker Switch
Circuit Rating	15 Amp, ATC Blade Fuse or similar (customer supplied)	15 Amp, ATC Blade Fuse or similar (customer supplied)
Sizes	8 - 21 ft 2.4 - 6.4 m	8 - 21 ft 2.4 - 6.4 m
Fabric Type	Vinyl	Vinyl
Fabric Pattern	Linen Fade	Linen Fade
Fabric Colors	Onyx, Sandstone	Onyx, Sandstone
Weathershield	Vinyl	Vinyl
Weathershield Colors	Polar White, Black	Polar White, Black
End Cap Colors	Polar White, Black	Polar White, Black

LED LIGHT*	
Count	30/meter
Color Temperature	Cool White
Lumens	2,400
Watts	36
LED Control	SPST ON-OFF Illuminated Rocker Switch

HARDWARE	STANDARD	BASEMENT
Model Series	89620X2	89620X1
Door Clearance	7.5 in / 19.1 cm	12.5 in / 31.75 cm
Arm Length	66.25 in / 168.3 cm	62.75 in / 159.4 cm
Drop	Approx. 13 in / 33 cm	Approx. 31 in / 78.8 cm
Manual Pitch Adjustment	Approx. 24 in / 61 cm	Approx. 24 in / 61 cm
Actuation	Gas Strut	Gas Strut
Hardware Colors	Polar White, Black	Polar White, Black

*Standard Equipment on 9200 PowerChannel Only

POWERCHANNEL ACCESSORIES

Turn on relaxing ambient music under your Dometic awning with this Bluetooth-enabled PowerChannel Speaker.



**USE MULTIPLE DEVICES
SIMULTANEOUSLY**

EASY SETUP

BLUETOOTH-ENABLED

LET THE MUSIC PLAY



Add to your outdoor living enjoyment with a Dometic PowerChannel Speaker. It connects easily to both the PowerChannel and a bluetooth music device. With this innovative solution you can add your favorite tunes to create the perfect atmosphere, wherever you are and whatever you are doing!

KEY BENEFITS

- Play songs wirelessly with the Bluetooth-enabled speakers
- Easy quarter turn fastening for Dometic awning accessories
- Use speaker simultaneously with other connected devices
- For use with the patented Dometic PowerChannel Awning

ADDITIONAL POWERCHANNEL ACCESSORIES: ALL THE FUN NONE OF THE CORDS



DOMETIC POWERCHANNEL FAN

Make your awning shade even cooler with the Dometic PowerChannel Fan. Connects directly to PowerChannel Awning rail for easy, breezy comfort.



DOMETIC POWERCHANNEL DUAL SPEAKER

Turn on relaxing ambient music under your Dometic awning with this Bluetooth-enabled PowerChannel Dual Speaker.



DOMETIC POWERCHANNEL FLOODLIGHT

Enjoy your Dometic awning even on the darkest of nights with the Dometic PowerChannel Floodlight. Enjoy the great outdoors no matter what time it is.



DOMETIC POWERCHANNEL SPOTLIGHT

Add some light to your card game, meal, while reading or any other awning-covered activity with the Dometic PowerChannel Spotlight.



DOMETIC POWERCHANNEL USB CHARGER

Keep your electronics fully-charged with the Dometic PowerChannel USB Charger. Compatible with the Dometic PowerChannel Awning and Rail.

DOMETIC TRIMLINE II BAG AWNING

The Dometic Trim Line II Bag Awning is a terrific way to shade your living space at an affordable price. Featuring a robust frame with easy to lock legs for your convenience.



EASY SETUP
NO TOOLS REQUIRED

PROTECTS

HIGHLY DURABLE

SIMPLE SHADE



Enjoy the outdoors with shade. The Dometic TrimLine II Bag Awning is a terrific way to expand your living space at a very affordable price. Turn your TrimLine II awning into a scenic patio in just minutes and say good riddance to the burning sun. Ideal for dining, sleeping, or just relaxing. As easy to take down as it is to put up, the TrimLine II Bag Awning folds neatly into its own storage bag when you're ready to hit the road.

KEY BENEFITS

- Polycord sewn in – bag slides into awning rail
- All parts stow in zippered bag
- Adjustable support poles and click-lock poles

VINYL LINEN FADE



Sandstone
Color Code: NS

Azure
Color Code: NT

Bark
Color Code: NU

Maroon
Color Code: NV

Onyx
Color Code: NR

Meadow Green
Color Code: NW

DOMETIC FAN-TASTIC VENT 1400 / 1450 HIGH-POWERED VENT FAN

The Dometic Fan-Tastic Vent 1400/1450 Vent Fan has a new modern look. This lightweight, compact and durable unit seals tight when not in use. Powerful 12 in, 10-blade fan quickly moves air out of the cabin. Includes integrated tabs for mounting a Dometic Ultra Breeze cover.



3-SPEED FAN

**LESS THAN 3.0 AMP
DRAW ON HIGH**

**EASY TO
INSTALL**

THE FUTURE OF HIGH-POWERED RV VENTILATION



KEY BENEFITS

- Three fan blade speeds (low, medium, high)
- Manual life dome
- Quiet operation
- Fits standard 14 in X 14 in openings
- White high profile universal base
- Will operate with the lid closed
- Comes with a smoke polycarbonate lid

SPECIFICATIONS

ITEM NUMBER	1400/1450
DIMENSIONS	Width: 18.72"
	Depth: 16.44"
	Height: 5.76"
INSTALLED WEIGHT	7.5 lbs



3-SPEED

Thermally protected analog switch



CEILING FAN OPERATION

Fan will run with lid closed



LIGHT WEIGHT

Increased structural support



INTEGRATED MOUNTING BRACKETS

Allows for easy vent cover installation with no drilling necessary



POP N LOCK SCREEN

Easy removal for cleaning



OPEN & CLOSE

Manual operation to raise and lower the lid

DOMETIC MOJAVE SERIES RV FURNACES

Engineered for easy maintenance and superior air delivery. Its compact size offers installation convenience. The Dometic Mojave Furnace now comes with a durable stamped steel door that is built to last (select models only).



LOW-PROFILE

QUIET

**FLEXIBLE
INSTALLATION**

STAY WARM WITHOUT BEING DISTURBED



The Dometic Mojave Series furnace is a compact, lightweight heater boasting a quiet operation thanks to reduced air turbulence. For easy and flexible installation, it may be placed vertically or horizontally. With the most duct configurations on the market, you can distribute heat exactly as you need it. Access door and thermostat sold separately.

KEY BENEFITS

- Horizontal or vertical configuration for flexible installation
- Quiet operation thanks to reduced air turbulence
- Low-profile, compact design
- 12,000 - 40,000 BTU/hr
- Outside access door required
- Easy operation using one button
- Available in doored or door-less models

TECHNICAL DATA

SKU/ITEM NUMBERS	DESCRIPTION	BTU	GAS	DIMENSIONS*	INPUT VOLTAGE	WEIGHT
9600001143 / 38916	DFS - Small Doored Furnace	12,000	LP gas	H: 7 in x W: 12 in x D: 20 in	12 V DC	21 lbs
9108923339 / 38917	DFS - Small Doored Furnace	16,000	LP gas	H: 7 in x W: 12 in x D: 20 in	12 V DC	21 lbs
9600001165 / 38918	DFS - Small Doored Furnace	18,000	LP gas	H: 7 in x W: 12 in x D: 20 in	12 V DC	21 lbs
9600001146 / 38920	DFS - Small Door-less Furnace	12,000	LP gas	H: 7 in x W: 12 in x D: 20 in	12 V DC	21 lbs
9600001156 / 38921	DFS - Small Door-less Furnace	16,000	LP gas	H: 7 in x W: 12 in x D: 20 in	12 V DC	21 lbs
9108923341 / 38922	DFS - Small Door-less Furnace	18,000	LP gas	H: 7 in x W: 12 in x D: 20 in	12 V DC	21 lbs
9600000823 / 35526	DFM - Medium Doored Furnace	20,000	LP gas	H: 7 in x W: 16.5 in x D: 20 in	12 V DC	26 lbs
9600000886 / 35525	DFM - Medium Doored Furnace	25,000	LP gas	H: 7 in x W: 16.5 in x D: 20 in	12 V DC	26 lbs
9600000923 / 35524	DFM - Medium Doored Furnace	30,000	LP gas	H: 7 in x W: 16.5 in x D: 20 in	12 V DC	26 lbs
9108923309 / 35522	DFM - Medium Doored Furnace	35,000	LP gas	H: 7 in x W: 16.5 in x D: 20 in	12 V DC	26 lbs
9600000798 / 35521	DFM - Medium Door-less Furnace	16,000	LP gas	H: 7 in x W: 16.5 in x D: 20 in	12 V DC	26 lbs
9600000827 / 35520	DFM - Medium Door-less Furnace	20,000	LP gas	H: 7 in x W: 16.5 in x D: 20 in	12 V DC	26 lbs
9600000890 / 35519	DFM - Medium Door-less Furnace	25,000	LP gas	H: 7 in x W: 16.5 in x D: 20 in	12 V DC	26 lbs
9600000926 / 35518	DFM - Medium Door-less Furnace	30,000	LP gas	H: 7 in x W: 16.5 in x D: 20 in	12 V DC	26 lbs
9600001058 / 35516	DFM - Medium Door-less Furnace	35,000	LP gas	H: 7 in x W: 16.5 in x D: 20 in	12 V DC	26 lbs
9108923369 / 38359	DFL - Large Doored Furnace	40,000	LP gas	H: 9 in x W: 16.5 in x D: 20 in	12 V DC	39 lbs
9600001221 / 38363	DFL - Large Doored Furnace	35,000	LP or Natural gas	H: 9 in x W: 16.5 in x D: 20 in	115 V AC	39 lbs
9108923372 / 38362	DFL - Large Doored Furnace	40,000	LP or Natural gas	H: 9 in x W: 16.5 in x D: 20 in	115 V AC	39 lbs
9600001239 / 38356	DFL - Large Door-less Furnace	35,000	LP gas	H: 9 in x W: 16.5 in x D: 20 in	12 V DC	39 lbs
9108923366 / 38355	DFL - Large Door-less Furnace	40,000	LP gas	H: 9 in x W: 16.5 in x D: 20 in	12 V DC	39 lbs
9600001224 / 38358	DFL - Large Door-less Furnace	35,000	LP or Natural gas	H: 9 in x W: 16.5 in x D: 20 in	115 V AC	39 lbs
9108923368 / 38357	DFL - Large Door-less Furnace	40,000	LP or Natural gas	H: 9 in x W: 16.5 in x D: 20 in	115 V AC	39 lbs

*Units dimensions, not the cutout dimensions

Contents, specifications and availability are subject to change in the interests of technical improvement.

- / DROP-IN COOKTOP
- / SLIDE-IN COOKTOP
- / 3-BURNER RANGES
- / AMERICANA & AMERICANA PLUS REFRIGERATORS
- / CRX SERIES 3-IN-1 REFRIGERATORS
- / CD DRAWER REFRIGERATORS

FOO BEVE





D & RAGE

DOMETIC DROP-IN COOKTOP

The Dometic Drop-In Cooktop makes a great addition to any mobile living space, truck camper, or outdoor kitchen. With two burners, multiple ignition types and an optional cast iron or flat wire grate. Enjoy the comfort of hot meals, wherever you are.



**INCREASE
WORK SPACE**

PRECISE CONTROLS

EASY TO CLEAN

HOT MEALS ON THE ROAD



The Dometic Drop-In cooktop has a powerful 7,200 and 5,200 BTU burner, allowing you to conveniently prepare a main dish and side dish simultaneously. The recessed control panel and burner knobs are easy to use and allow you to cook with precision. The one-piece surface ensures the cooking area is easy to clean. Optional dark glass or steel covers with wind guards both protect your cooktop and increase work space when the cooktop is not in use. It's the ideal cooking companion, wherever you are!

KEY BENEFITS

- Linear flow gas valves allow you to cook with precision
- One-piece surface and sealed burners ensure a cleaner cooking area
- The 7,200 BTU burner offers plenty of power for cooking all types of food
- The 5,200 BTU burner is perfect for preparing your side dishes simultaneously
- Optional glass or steel cover adds works space when the cooktop is not in use
- Part of Dometic's Signature Suite of Kitchen Appliances



HIGH OUTPUT

Large sealed burner head with aluminum cap



WITHIN EASY REACH

Black porcelain cooking surface with recessed knobs and Piezo ignition



MORE SPACE FOR COOKING

Recessed design with full width one-piece grates

DOMETIC SLIDE-IN COOKTOP

Have it all: style and performance! This Cooktop will make a great addition to any motor home or towable RV. Enjoy the comfort of a hot meal, wherever you are.



**INCREASE
WORK SPACE**

PRECISE CONTROLS

**EASY TO CLEAN
SEALED BURNERS**

A SMART SOLUTION FOR COOKING ON THE ROAD



The Dometic Slide-In Cooktop has a powerful 9,000 BTU burner plus two 6,500 BTU burners, allowing you to prepare a main dish and side dish simultaneously with ease. Recessed burner knobs are easy to use and allow you to cook with precision. A one-piece surface ensures a cleaner cooking area. Optional steel or flush glass bi-fold cover both protect your cooktop and increase work space when the cooktop is not in use. The ideal cooking companion, wherever you are.

KEY BENEFITS

- Linear flow gas valves allow you to cook with precision
- One-piece surface and sealed burners ensure a cleaner cooking area
- 9,000 BTU burner offers plenty of power for cooking all types of food
- The two 6,500 BTU burners are perfect for preparing your side dishes simultaneously
- One-piece full width flat wire or optional cast iron grate increases total cooking area
- Optional glass or steel cover adds work space when the cooktop is not in use
- Part of Dometic's Signature Suite of Kitchen Appliances



HIGH OUTPUT

Stainless Steel cooktop with high output sealed burners



COOK WITH PRECISION

One piece burner top with recessed knobs & Piezo ignition



MORE SPACE FOR COOKING

Large flat wire or cast iron grate with no slip surface

DOMETIC 3-BURNER RANGES

Enjoy the comfort of home cooking while you're on the road. The Dometic 3 Burner Range has a centralized high output burner and improved flame distribution. The one-piece cast iron or flat wire grate construction gives 33% more usable surface area for pots and pans. With an ergonomic oven handle and optional stainless steel insert.



**MORE USABLE
SURFACE AREA**

POWERFUL HEAT
9,000 BTU

EASY TO CLEAN

HOME COOKING ON THE ROAD



The Dometic Oven Range 3-burner is equipped with Piezo ignition and flat wire or cast iron one-piece grates. Sealed burners prevent spills from collecting under the range top and make cleaning easier. The high output in the front and rear burners cook food quickly. Includes built in broiler and toaster. The centralized high output burner location allows for the convenient use of a variety of pots and pans. The residential-like port configuration provides better flame distribution to cook food more evenly. Optional flush glass lid or steel top maximizes work space when not in use.

KEY BENEFITS

- Powerful 9,000 BTU front burner
- Sealed burners make cleaning easier
- Linear Burner Valves are easily adjusted on all burners for a wide range of flame settings
- 6,500 BTU rear burners are great for simultaneously cooking side dishes
- Piezo igniter makes lighting the range easier
- Recessed control knobs
- Optional flush glass bi-fold cover or steel top maximizes work space when not in use
- Part of Dometic's Signature Suite of appliances

TECHNICAL DATA

SKU/ITEM NUMBERS	DESCRIPTION	BTU	IGNITION	GRATE	DIMENSIONS	WEIGHT
9600005499 / 50422	3-Burner 17" black range	Front burner - 9,000 Rear burners - 6,500	Piezo	One piece Flat wire	17" cut-out: (H x W x D) 16" x 20.25" x 17.75"	53 lbs
9600005506 / 50429	3-Burner 17" stainless steel range	Front burner - 9,000 Rear burners - 6,500	Piezo	One piece Flat wire	17" cut-out: (H x W x D) 16" x 20.25" x 17.75"	53 lbs
9600005517 / 50442	3-Burner 21" black range	Front burner - 9,000 Rear burners - 6,500	Piezo	One piece Flat wire	21" cut-out: (H x W x D) 20" x 20.25" x 17.75"	58 lbs
9600005522 / 50447	3-Burner 21" stainless steel range	Front burner - 9,000 Rear burners - 6,500	Piezo	One piece Flat wire	21" cut-out: (H x W x D) 20" x 20.25" x 17.75"	58 lbs
9600005500 / 50423	3-Burner 17" black range	Front burner - 9,000 Rear burners - 6,500	Piezo	One piece Cast iron	17" cut-out: (H x W x D) 16" x 20.25" x 17.75"	53 lbs
9600005507 / 50430	3-Burner 17" stainless steel range	Front burner - 9,000 Rear burners - 6,500	Piezo	One piece Cast iron	17" cut-out: (H x W x D) 16" x 20.25" x 17.75"	53 lbs
9600005518 / 50443	3-Burner 21" black range	Front burner - 9,000 Rear burners - 6,500	Piezo	One piece Cast iron	21" cut-out: (H x W x D) 20" x 20.25" x 17.75"	58 lbs
9600005523 / 50448	3-Burner 21" stainless steel range	Front burner - 9,000 Rear burners - 6,500	Piezo	One piece Cast iron	21" cut-out: (H x W x D) 20" x 20.25" x 17.75"	58 lbs

DOMETIC AMERICANA AND AMERICANA PLUS

Dometic Americana Double Door Refrigerators feature two-way power (110 V AC or LP Gas) in 6 or 8 cu. ft. capacities. A solid steel frame construction and automatic electronic LP ignition system make this one of the best built RV refrigerators on the road.



TWO-WAY POWER
AC OR LP GAS

FLEXIBLE STORAGE

LED LIGHTING
BRIGHT AND EFFICIENT

AN IDEAL COOLING SOLUTION FOR LIFE ON THE ROAD



The Dometic Americana is at the head of the Dometic double door family of RV refrigerators. Completely redesigned from top to bottom, this refrigerator still remains at an affordable price while sporting many features and benefits. This Dometic refrigerator includes an adjustable shelving system and three-position freezer shelf. Powered by either 110 V AC or LP Gas, it gives users the freedom to travel anywhere! Electronic controls are conveniently located inside the refrigerator. The doors can be securely locked using the integrated one-step, ergonomic handles – perfect for bumpy rides!

KEY BENEFITS

- The new LED light increases the interior brightness by 30%
- Convenient storage thanks to the flexible shelving system
- Two-way operation (AC or LP Gas) offers flexibility
- Edge-to-edge full width doors
- Electronic controls with automatic LP ignition
- Two extra wide crisper bins with built-in carry handles
- Ergonomic integrated locking door handles keep contents safe
- Part of Dometic's Signature Suite of Kitchen Appliances



NEW BRIGHTER LED LIGHT

New LED light fixture illuminates interior more brilliantly.



EYE LEVEL ELECTRONIC CONTROL

Interior controls with automatic electronic ignition and adjustable temperature control (Americana Plus).



EASY GRIP

Large modern ergonomic handle with positive lock.

CRX SERIES 3-IN-1 REFRIGERATORS

CRX built in refrigerators are quiet, flexible and efficient. The patented removable freezer transforms the CRX into a refrigerator only, or a freezer only with temperature going down to 17° F / -8° C.



3-IN-1 SOLUTION
REFRIGERATE, FREEZE OR BOTH

HIGHLY EFFICIENT

MAXIMIZE SPACE
BEVELED EDGE



12/24 V



100 - 240 V



QUIET

*Except for the 110

REFRIGERATE, FREEZE OR BOTH AT THE SAME TIME



The CRX Series is a veritable chameleon. It's all fridge, it's all freezer, or it's a fridge-freezer. You decide. The patented easy-to-remove freezer compartment lets you choose how to use it and the soft-touch control panel lets you set the desired temperature. Smart electronics save energy by regulating the compressor speed for maximum efficiency.

KEY BENEFITS

- Patented removable freezer compartment
- Offering a 3-in-1 solution: fridge, freezer or both at the same time!
- Temperature control and compressor speed control enable highly efficient energy consumption
- Beveled edge on the backside for optimal utilization of space on board
- Minimal noise as the fan speed automatically adjusts to the ambient temperature
- Standard or flush-mount installation frame available as accessory
- Dual function locks can also act as vents for your fridge

CRX TECHNICAL DATA									
	Model	CRX-1050E	CRX-1050S	CRX-1065E	CRX-1065S	CRX-1080E	CRX-1080S	CRX-1110E ¹	CRX-1110S ¹
Total Storage Capacity (cf/l)		1.6/45		1.9/55		2.6/73		3.7/104	
Amps @ 12VDC		5		5.5		5.6		6.2	
Amps @ 24VDC		2.6		2.8		2.9		3	
Amps @ 100VAC		1.14		1.22		1.23		0.82	
Amps @ 240VAC		0.53		0.58		0.56		0.34	
Overall Flush-Mount Flange Dimensions (H x W x D)		22.25 x 17.875 x 19.75 in (556 x 524 x 502 mm)		21.875 x 20.625 x 21.5 in (556 x 524 x 547 mm)		26.375 x 21.625 x 21 in (670 x 550 x 534 mm)		30.5 x 23.375 x 22 in (775 x 594 x 559 mm)	
Flush-Mount Flange Cutout Dimensions (H x W x D)		21.375 x 16.125 x 19.75 in (543 x 410 x 502 mm)		21 x 18.875 x 21.5 in (534 x 480 x 547 mm)		25.5 x 19.875 x 21 in (648 x 505 x 534 mm)		29.625 x 21.625 x 22 in (753 x 550 x 559 mm)	
Overall Space Saver Flange Dimensions (H x W x D)		22.125 x 17.25 x 17.5 in (562 x 439 x 445 mm)		21.75 x 20 x 19.25 in (553 x 508 x 489 mm)		26.25 x 21 x 18.75 in (667 x 534 x 731 mm)		30.375 x 22.75 x 19.75 in (772 x 578 x 502 mm)	
Space Saver Flange Cutout Dimensions (H x W x D)		21.125 x 15.25 x 17.5 in (527 x 458 x 489 mm)		20.75 x 18 x 19.25 in (527 x 458 x 489 mm)		25.25 x 19 x 18.75 in (642 x 483 x 477 mm)		29.375 x 20.75 x 19.75 in (477 x 727 x 502 mm)	
Net Weight (lbs/kg)		35.3/16		39.7/18		44.1/20		60.86/28	
Colors Available		Black, Silver, Stainless Steel		Black, Silver, Stainless Steel		Black, Silver, Stainless Steel		Black, Silver, Stainless Steel	

¹ Freezer not removable

DOMETIC CD DRAWER REFRIGERATORS

The Dometic CD 20 built-in drawer refrigerator offer generous cold storage in a robust and compact package. It has a fully hermetic compressor with integrated electronic controls and a 12V operation with low voltage protection.



LOW PROFILE
LESS THAN 10 IN./254 MM HIGH

DC OPERATION
COVERED BACK

EASY-PULL DRAWER
BEARING SLIDES



12/24 V

CONVERT EMPTY SPACES INTO PRACTICAL COOLING



The Dometic CD 20 drawer refrigerator turns any unused nook, such as the space under a seat, into a practical 20/30l (21/31 quart) Capacity refrigerator. A convenient variable thermostat protects your contents from freezing, and the fully hermetic compressor is extremely energy efficient. The CD needs less than 10 in. of height for installation. The drawer handle is recessed for a smooth, sleek appearance. Make the most of space while you're on the road.

KEY BENEFITS

- Requires less than 10" of height for installation
- Fully hermetic compressor with integrated control electronics
- Easy-pull drawer on roller bearing slides
- Unlock and open with a single movement
- AC operation with covered back-plate
- Temperature regulation with continuously variable thermostat
- Handle with keyed lock

CD TECHNICAL DATA							
	Model	CD-020DC	CD-020DCW	CD-020DCS	CD-030DC	CD-030DCW	CD-030DCS
Storage Volume (cu ft/l)		0.71/20			1.06/30		
Amps @ 12V DC (A)		3			3		
Amps @ 24V DC (A)		1.5			1.5		
Power Consumption @ 12V DC (W)		36			40		
Temperature Range-Low (°F/C)		32/0			32/0		
Temperature Range-High (°F/C)		59/15			59/15		
Height (in/mm)		9.84/250			9.84/250		
Width (in/mm)		17.24/438			17.32/440		
Depth (in/mm)		22.24/565			28.74/730		
Net Weight (lb/kg)		35.5/16.1			39.68/18		

/ MODERNO TOILET

/ HANDWAVE TOILET CONTROL PANEL

HYGI SANIT





ENE & ATION

DOMETIC MODERNO TOILET WITH VARIFLUSH TECHNOLOGY

Dometic's new Moderno toilet with VariFlush technology is revolutionizing sanitation with its comfort, convenience, and innovative variability. The Moderno's residential styling, including an elongated seat, offers ease of use and comfort. A full ceramic bowl adds elegance and premium looks, while the innovative wall-mounted flush switch and slow-close seat ensure convenience.



EASY TO CLEAN

HANDWAVE TECHNOLOGY
TOUCHLESS OPERATION

COMFORTABLE
ELONGATED SEAT

PREMIUM LOOKS AND MAXIMUM CONVENIENCE

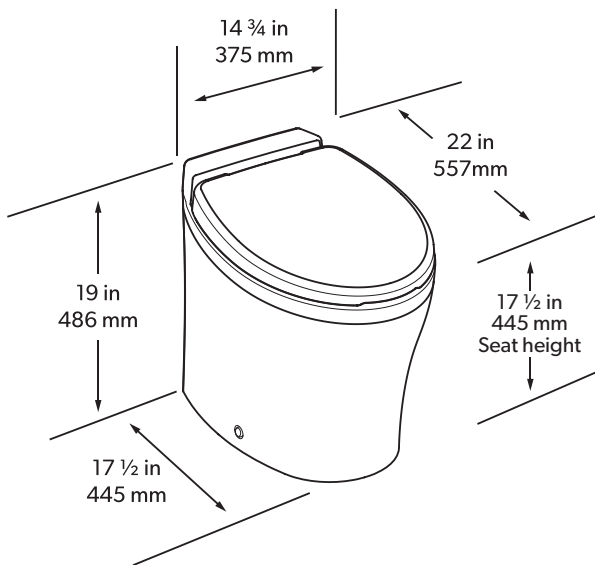

The new Dometic Moderno toilet comes fully equipped with VariFlush technology. A first in the industry, VariFlush technology allows a single bowl to accommodate multiple flushing technologies including: VacuFlush, MasterFlush, RushFlush, and Gravity. The Moderno toilet has an all-ceramic bowl that is elongated and tall to provide the luxurious comfort and feel of a residential toilet. The smooth contour, modern styling simplifies cleaning and improves hygiene. In addition, it has a slow-close seat that avoid unwanted bangs! Two color options are available for the Moderno toilet; white or bone. An optional bidet seat available in white only. The Dometic VFSHW Toilet Control Panel is available in black frame and is compatible with Vimar Eikon, Vimar Idea, and Gewiss Chorus frames. In addition, the Moderno uses Dometic's new HandWave Toilet Control Panel, allowing a user's simple hand gesture to flush or refill the toilet without physically touching anything, thereby reducing the spread of germs.

KEY BENEFITS

- Elongated and tall all ceramic bowl ensures user comfort
- Full ceramic bowl gives a premium look
- Modern styling with smooth contours for easy cleaning
- VariFlush technology enables various flushing technologies to be used
- Comes with the slow close seat and lid
- Convenient wall mounted flush switch
- Available in white and bone with the option of bidet seat



HANDWAVE CONTROLS

Touchless operations improves hygiene



SLOW CLOSE SEAT

Provide silent performance



EASY TO CLEAN

Smooth-contour bowl simplifies cleaning

DOMETIC VFSHW TOILET CONTROL PANEL

The Dometic VFSHW Toilet Control Panel, used in conjunction with the Moderno toilet, has HandWave motion sense technology and capacitive touch display that offers a fresh approach to lavatory use. The HandWave technology allows users to flush the toilet without touching the display, greatly improving hygiene! There are intuitive icons on the Control Panel that allow users to add water, flush, or service. These icons ensure easy operation and avoid language barriers. Each of the icons has backlighting for easy use in low light visibility. The Dometic VFSHW Toilet Control Panel is backward compatible. Boaters who want to upgrade to the Moderno toilet can replace an existing Control Panel without remodeling.



HYGIENIC AND CLEAN

**VIMAR AND GEWISS
COMPATIBLE**

**HANDWAVE
TECHNOLOGY**

HANDS FREE



The Dometic VFSHW Toilet Control Panel, used in conjunction with the Moderno toilet, has HandWave motion sense technology and capacitive touch display that offers a fresh approach to lavatory use. The HandWave technology allows users to flush the toilet without touching the display, greatly improving hygiene! There are intuitive icons on the Control Panel that allow users to add water, flush, or service. These icons ensure easy operation and avoid language barriers. Each of the icons has backlighting for easy use in low light visibility. The Dometic VFSHW Toilet Control Panel is backward compatible. Boaters who want to upgrade to the Moderno toilet can replace an existing Control Panel without remodeling.

KEY BENEFITS

- HandWave motion sense technology improves hygiene as users don't touch anything
- Capacitive touch display offers a fresh approach to lavatory use
- Easily replace existing switches without remodeling
- Backwards compatible control
- Comes with a backlighting feature



HANDWAVE CONTROLS

Touchless operations improves hygiene



BACKLIGHTING

Enhanced visibility in low light

Mobile living made easy.



FDD CUSTOMER SERVICE
1120 N. MAIN STREET
ELKHART, IN 46516
800.366.3842
DOMETIC.COM
L-5051 - 01.12.18